

CCI A3

ISOBUS AUX control

Operating instructions

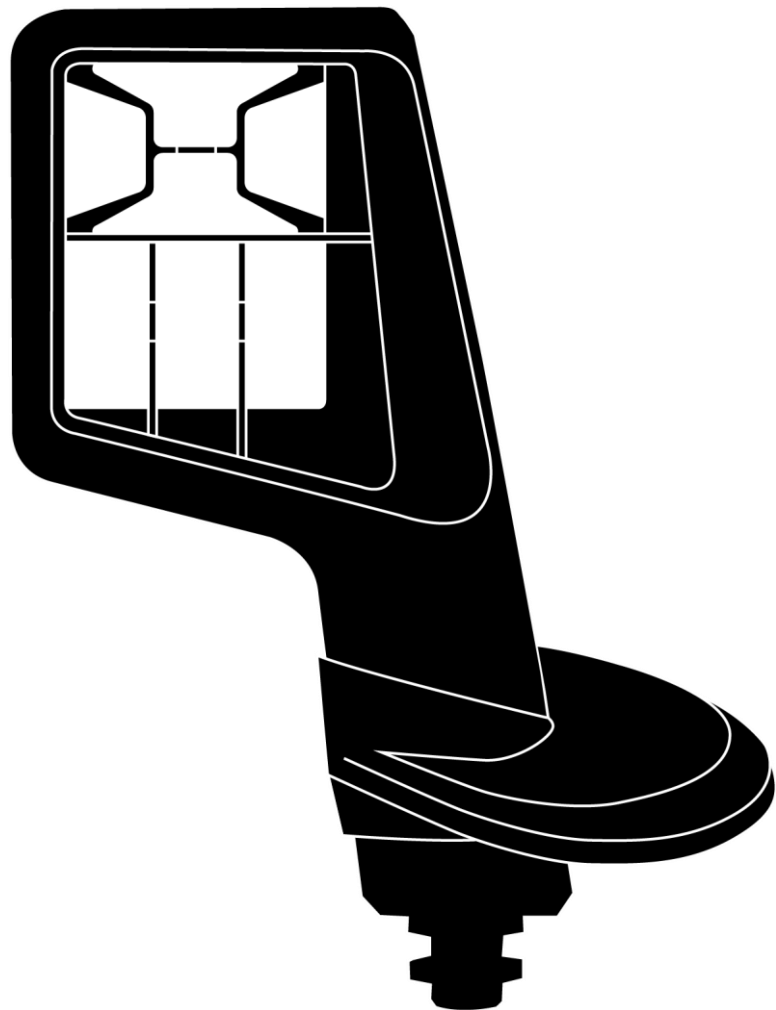

CCI ISOBUS
team play works.

17513758 (en)

Contents

About these operating instructions	2
Glossary	3
About the CCI A3	4
1 Safety	7
1.1 Identification of indications in the operating instructions	7
1.2 Intended use	8
1.3 Safety notes	8
2 Setting up for operation	10
2.1 Check the scope of delivery	10
2.2 Installing	11
2.3 Inserting the grid	11
2.4 Connecting	12
2.5 Switching on	13
2.6 Setting	13
3 Operation	14
3.1 Changing the operating level	14
3.2 Changing the grid	15
3.3 Changing the settings	16
3.4 Assigning implement functions to buttons	18
4 Troubleshooting	19
4.1 Problems during operation	20
5 Disposal	21

About these operating instructions

Target group

These operating instructions are intended for persons that are entrusted with the use of the *AUX control* CCI A3. They include all necessary information for safe handling of software and the *AUX control*.

All information provided in the operating instructions relates to the following device configuration:

Software version	1.0
Hardware version	2.0

These operating instructions guide you chronologically through operation:

- About the CCI A3
- Safety
- Setting up for operation
- Operation
- Troubleshooting
- Technical Information

Liability disclaimer

To ensure fault-free operation of your CCI A3, please read through the operating instructions carefully. Keep the operating instructions for future reference.

These operating instructions must be read and understood prior to assembly and commissioning of the CCI A3 to prevent problems during operation. No liability is accepted for damage resulting from failure to observe these operating instructions!

If problems arise

If you need further information or if problems occur that are not covered in enough detail in these operating instructions, then please contact your dealer to obtain the required information.

Glossary

Terminating resistor	If no <i>ISOBUS participant</i> (e.g. an ISOBUS Terminal) is connected to the ISOBUS <i>plug</i> of the CCI A3, a <i>terminating resistor</i> must be plugged into the cable end. This is contained in the scope of delivery of the CCI A3.
AUX control	<i>AUX controls</i> are typically joysticks or toggle switch strips. An <i>AUX control</i> enables the comfortable and efficient handling of frequently used implement functions.
AUX assignment	If, in addition to the <i>terminal</i> and <i>implement</i> the CCI A3 is connected to the ISOBUS, implement functions can be performed using the CCI A3. For this purpose, operating elements of the CCI A3 must have been assigned implement functions. This process is referred to as <i>AUX assignment</i> .
Operating screen	The graphical user interface visible on the ISOBUS terminal of the CCI A3. The <i>AUX assignment</i> can be checked here. or The <i>buttons</i> portrayed on the display of the CCI A3.
CCI	Competence Center ISOBUS e.V.
In-cab	Term from the standard ISO 11783. Describes the nine-pole ISOBUS panel connector in the tractor cab.
ISOBUS	ISO 11783 International standard for data transfer between farming implements and devices.
Implement	Towed or attached implement. An implement with which a task can be executed.
ISOBUS participant	A device that is connected to the ISOBUS and communicates via this system.
Coupling	Female connector on the end of a cable.
Button	Operating element in the third operating level or the settings of the CCI A3, is activated by pressing the <i>touchscreen</i> .
Plug	Male connector on the end of a cable.
Terminal	ISOBUS terminal
Touchscreen	Touch-sensitive display of the CCI A3, via which it is possible to operate the implement functions and adjust the <i>AUX control</i> .
UT	The Universal Terminal is the human machine interface (HMI) of ISOBUS. This is the display and operating device. Each <i>implement</i> connected to the ISOBUS logs on to the UT and uploads its Object Pool. You operate the <i>implement</i> via the operating screens of the Object Pool.

About the CCI A3

The CCI A3 is a manufacturer-independent ISOBUS *AUX control* for handling implement functions.

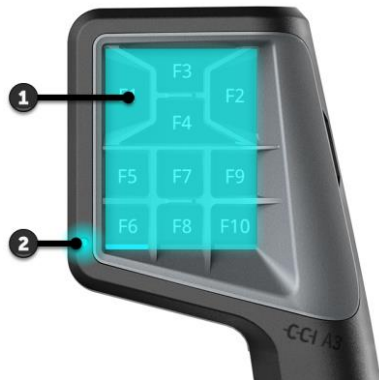

1. *Touchscreen*
2. Light sensor



3. Level pushbutton

Touchscreen

The CCI A3 is operated via the *touchscreen*. The display brightness can be adjusted.

Vibration feedback

Pressing a *button* on the CCI A3 gives vibration feedback. The intensity of the vibration can be adjusted.

Operating levels

The CCI A3 has three operating levels and so enables handling of more implement functions.

One *button* can be assigned one implement function in each operating level.

The buttons in the operating levels are labelled F1, F2, F3, etc.



NOTE

Implement-specific pictogram to prevent incorrect operation.

Some implements replace the generic labelling of the buttons with the pictogram of the implement function. The *implement* automatically uploads the pictogram into the CCI A3.

→ The probability of calling an incorrect implement function is reduced.

Pressing the level pushbutton on the rear side of the casing, switches you to the next operating level.

Level push-button

The grids differ in respect of the number and arrangement of buttons. Grids are used to optimally match the CCI A3 to *implement* and application. The separating strips, delimit the buttons from each other in a tactile manner.

Grids

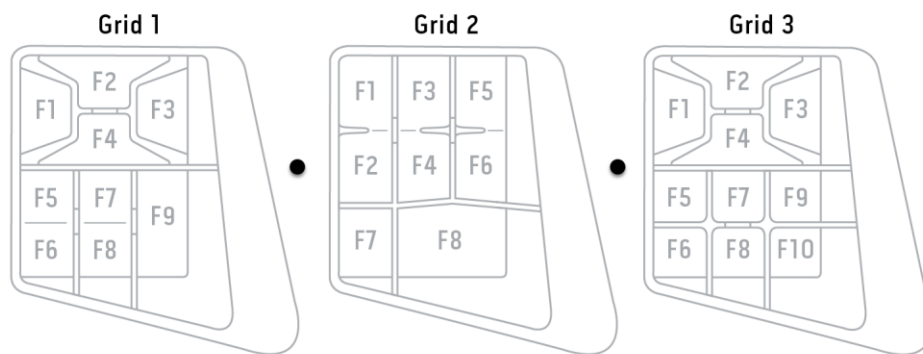

Identify your device based on the information on the nameplate. The nameplate is attached to the cable.

Nameplate

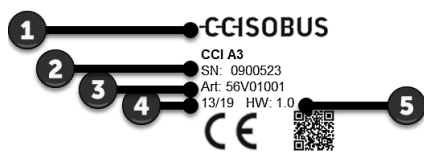

1. Manufacturer
2. Serial number
3. Manufacturer's article number
4. Production date (week/year)
5. Hardware version



NOTE

The layout and content of the nameplate on your *terminal* may differ from that shown in the figure.

The nameplate is attached by the manufacturer.

Technical Information

Dimensions (B x H x D) [mm]	225 x 110 x 50
Casing Type	Glass fibre reinforced polyamide
Fastening	M16 x 1
Operating Temperature [°C]	-15 - +70
Supply voltage [V]	12 VDC or 24VDC
Permitted Range [V]	7.5 VDC - 32VDC
Display [inch]	3.5 TFT
Storage temperature [°C]	-15 - +70
Weight [gr]	740
Protection class	IP65
EMC	ISO 14982
ESD protection	ISO 10605:2008

AEF functionalities

With each new version, the CCI A3 undergoes the AEF conformity test and is certified for the following AEF ISOBUS functionalities:



Universal Terminal

So that with an ISOBUS terminal, the operating elements of the CCI A3 can be assigned implement functions.



Auxiliary Control (new)

For the handling of frequently used implement functions with the CCI A3.

- ▶ The *implement* and the ISOBUS terminal must be certified according to AUX-N.

1 Safety

These operating instructions contain basic instructions which must be observed during setting up, configuration and operation. As such, it is absolutely essential to read these operating instructions prior to setting-up, configuration and operation.

Not only do the general safety indications listed in this chapter have to be observed but also the special safety indications appearing in other chapters as well.

1.1 Identification of indications in the operating instructions

The warning notes in these operating instructions are specially identified:



WARNING - GENERAL HAZARDS!

This warning symbol identifies general warning notes the non-observance of which poses a danger for life and limb.

► Strictly observe the warning notes and take particular care in these cases.



CAUTION!

This caution symbol identifies all warning notes referring to regulations, directives or working procedures which must be observed.

Non-observance can result in damage to or the destruction of the CCI A3, as well as malfunctions.

You can find tips for use in the "Notes":



NOTE

The note symbol highlights important and useful information.

1.2 Intended use

CCI A3 is intended exclusively for use with approved ISOBUS implements and devices in agriculture. Any other installation or use of the CCI A3 is not included within the manufacturer's area of responsibility.

The manufacturer accepts no liability for any resulting personal injury or material damage. Any risks for unintended use are borne solely by the user.

Observance of the operation and maintenance conditions stipulated by the manufacturer also form part of intended use.

The accident prevention regulations in force, as well as other generally recognised safety, industrial, medical and traffic laws must be observed. Unauthorised modifications to the device exclude the manufacturer's liability.

1.3 Safety notes



WARNING - GENERAL HAZARDS!

Please take special care to ensure the following safety instructions are complied with.

Non-compliance could result in malfunctions and consequently danger for any bystanders.

- ▶ Only switch the CCI A3 off, if
 - the touchscreen does not react or
 - the level button does not function.
 - ▶ Ensure that the *touchscreen* is dry before working with the terminal.
 - ▶ Do not operate the CCI A3 whilst wearing gloves.
 - ▶ Ensure the CCI A3 does not exhibit any external damage.
 - ▶ Insert the grid, before you carry out the *AUX assignment*.
 - ▶ Do not change the grid, while you are operating the *implement* with the CCI A3.
-



BASIC SAFETY INSTRUCTIONS

Please also observe the following safety instructions.

If they are not observed, the CCI A3 could be damaged.

- ▶ Do not open the casing of the CCI A3. Opening the casing can result in a reduced CCI A3 service life and malfunctions. If the CCI A3 casing is opened, the warranty will become void.
 - ▶ Disconnect the power supply to the CCI A3,
 - during welding work on the tractor or on a towed *implement*,
 - during maintenance on the tractor or on a towed *implement*,
 - when a charger is connected to the battery of the tractor.
 - ▶ Learn how to use the CCI A3 in accordance with regulations.
 - ▶ Keep the CCI A3 and accessories in good condition.
 - ▶ Only use a soft cloth moistened with clean water or a small amount of glass cleaning agent to clean the CCI A3.
 - ▶ Do not operate the *touchscreen* with a sharp-edged or rough object.
 - ▶ Do not exceed the temperature range of the CCI A3.
 - ▶ Keep the light sensor clean.
 - ▶ If the CCI A3 is not fitted in the cab, it should be stored in a dry and clean location. Do not exceed the storage temperature range.
-

2 Setting up for operation

- ▶ Start up the CCI A3 in the specified sequence.

2.1 Check the scope of delivery

Check the scope of delivery of your CCI A3 before you start setting up for operation:

- *AUX control*
- 3 grids
- *Terminating resistor*
- Quick guide
- Protective film for the display
- Assembly kit



NOTE

The device purchased by you may include other accessories.

The scope of delivery is defined by the manufacturer. The delivery accessories referred to above must be present in all cases.

- ▶ Speak to the dealer, if the scope of delivery is not complete.
-

2.2 Installing

The device holder forms part of the scope of delivery. Install the CCI A3 as follows:



NOTE

The CCI A3 must be correctly installed.

- ▶ Install the CCI A3 so that it
 - Is easy to read and operate and
 - Does not impede access to the tractor controls.

2.3 Inserting the grid

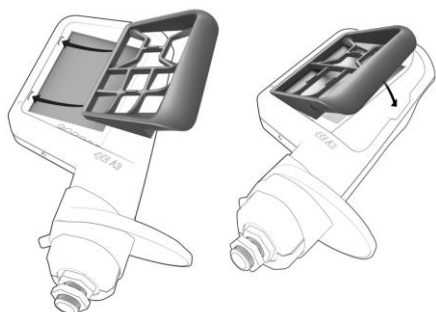

1. Insert the two pegs on the grid into the grooves in the casing of the CCI A3.
2. Fold the grid down.
→ The CCI A3 recognises the grid automatically and adjusts the number and arrangement of buttons.

2 Setting up for operation

2.4 Connecting

You connect the CCI A3 with the ISOBUS and supply it with current via the fixed cable on the CCI A3:

- ▶ Screw the *terminating resistor* to the *in-cab plug* of the cable.
- ▶ Plug the *in-cab coupling* of the cable into the *in-cab* panel connector of the tractor.
 - The CCI A3 is supplied with power via the *in-cab* panel connector and starts automatically.

You can connect an extra *ISOBUS participant* to the *plug* of the *in-cab* cable, e.g. an ISOBUS terminal:

1. Remove the *terminating resistor* from the *in-cab plug* of the cable.
2. Connect the *ISOBUS participant* to the *in-cab plug* of the cable.



NOTE

Always use the *in-cab plug* on the fixed cable.

An open *in-cab plug* can result in the CCI A3 not being found by other *ISOBUS participants*.

- ▶ Plug the *terminating resistor* in at the cable end, if you are not connecting any other *ISOBUS participant*.
-

2.5 Switching on

The CCI A3 starts automatically when it is supplied with power. The CCI A3 does not have an ON/OFF switch.

Before you can work with the CCI A3, you must answer the confirmation query. The confirmation query is used to determine, whether the *touchscreen* is functioning correctly.

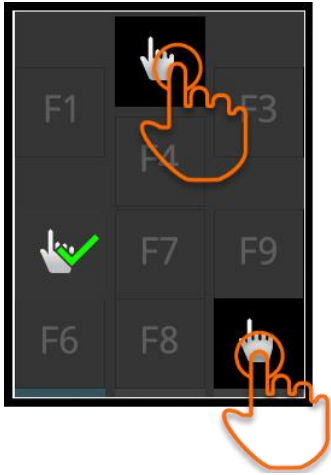

- ▶ Press on the "Press here" buttons in any order.
 - A green tick is displayed on the buttons.
 - Operating level 1 is displayed after you have pressed all 3 buttons.

2.6 Setting

Ex works, the vibration feedback and touch sounds are set to the maximum value.

Adapt the CCI A3 to match your preferences:



1. Press the level button and maintain it pressed for 3 seconds.
 - The "Settings" *operating screen* is displayed.
2. Press the *button* "Reduce feedback" repeatedly until the desired value is obtained.
3. Press the *button* "Reduce volume" repeatedly until the desired value is obtained.
4. End the process with "Back".

3 Operation

You will learn

- How to change between the three operating levels,
- How and when to change the grid and
- How you change the settings.

You operate the *implement* with the buttons on the *touchscreen*.

3.1 Changing the operating level

One *button* can be assigned one *implement* function in each operating level. Switch to the next operating level by pressing the level pushbutton on the rear side of the casing.

You use the level pushbutton for the *AUX assignment* and for *implement* operation:

- During the *AUX assignment*, change the operating level to be able to assign a different *implement* function to a *button*.
- During *implement* operation, change to the operating level with the desired *implement* function.

- ▶ Press on the level pushbutton.
 - The blue bar at the bottom edge of the displays jumps a position further and indicates in which level you are.



3.2 Changing the grid

If you want to change the number and arrangement of the buttons, insert the appropriate grid.



WARNING - GENERAL HAZARDS!

Do not change the grid during running.

During changeover of the grid, the CCI A3 logs off the ISOBUS and the connection to the *implement* is interrupted.

- Implement functions are no longer assigned to the buttons.
- You can no longer operate the *implement* with the CCI A3.

▶ Insert the grid, before you connect the *implement*.



NOTE

Grids are not implement-dependent.

Grids and implements can be freely combined.



1. Pull up the grid at the right and pull out.
2. Select another grid.

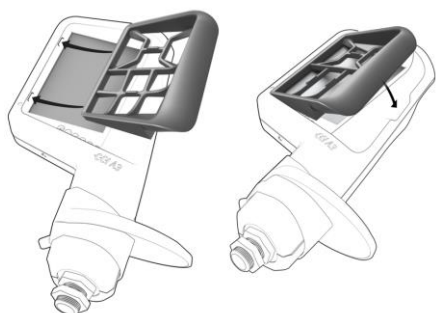

3. Insert the two pegs on the grid into the grooves in the casing of the CCI A3.
4. Fold the grid down.
→ The CCI A3 logs into the ISOBUS again.

3.3 Changing the settings

- ▶ Press the level button and maintain it pressed for 3 seconds.
→ The "Settings" *operating screen* is displayed.

The serial number of the device and the version numbers of the hardware and software are displayed.

You have the following setting options:



Reduce the volume of the touch sound

- ▶ Press the "Reduce volume" *button*.
→ Each press on the *button* reduces the touch sound until no touch sound is output.
-



Increasing the volume of the touch sound

- ▶ Press the "Increase volume" *button*.
→ Each press on the *button* increases the touch sound until the maximum value is reached.
-



Reducing the vibration feedback

- ▶ Press the "Reduce feedback" *button*.
→ Each press on the *button* reduces the vibration feedback until no vibration feedback is felt.
-



Increasing the vibration feedback

- ▶ Press the "Increase feedback" *button*.
→ Each press on the *button* increases the vibration feedback until the maximum value is reached.
-



Automatically adjusting the display brightness

The light sensor measures the ambient light and matches the display brightness to the ambient light.

- ▶ Press the *button* "Automatic display brightness".
→ In high ambient light, e.g. direct sunlight, the display brightness is increased.
→ In dim ambient light, e.g. during night-time operation, the display brightness is reduced.
-



Reducing display brightness

- ▶ Press the "Reduce brightness" *button*.
 - Each press on the *button* reduces the display brightness until the minimum value is reached.
-



Increasing display brightness

- ▶ Press the "Increase brightness" *button* .
 - Each press on the *button* increases the display brightness until the maximum value is reached.
-



Exiting the settings area

- ▶ End the process with "Back".
 - Your changes are applied.
 - The buttons for implement operation are displayed.

3.4 Assigning implement functions to buttons

You can execute 27 (grid 1), 24 (grid 2) or 30 (grid 3) implement functions using the CCI A3. You carry out the *AUX assignment* on the ISOBUS terminal.

1. Insert a grid.
2. Assign implement functions to the buttons of the CCI A3 as described in the terminal operating instructions.



NOTE

Changing the grid requires a new *AUX assignment*.

As the grids differ in the number of buttons, an *AUX assignment* must be performed for each grid.

→ If you perform an *AUX assignment* and then change the grid, the *AUX assignment* must be repeated.



NOTE

An *AUX control* requires a UT number "1".

The *AUX control* only connects to a UT if this has logged on to the ISOBUS using the UT number "1".

▶ On the ISOBUS terminal which is to connect to the CCI A3, set the UT number to "1".



NOTE

The *implement* saves the *AUX assignment*.

The *AUX assignment* must only be performed once.

→ The *AUX assignment* is available again after a restart of the *implement* and the CCI A3.

Not all implements can save the *AUX assignment* for each of the three grids.

→ In this case, after each change of the grid, the *AUX assignment* must be repeated.

4 Troubleshooting



CAUTION!

If a technical failure occurs, the work process must be interrupted.

Continuation of working after technical failures can result in damage to the CCI A3 or the *implement*.

1. Stop working.
 2. Look for a solution in this chapter of the operating instructions.
 3. Contact your dealer if the problem persists.
-

In the event of a fault, the CCI A3 may no longer respond to user inputs.

Forced shut-down

1. Unplug the *in-cab coupling* of the cable from the *in-cab* panel connector of the tractor.
→ The power supply is interrupted and the CCI A3 is switched off.
2. Plug the *in-cab coupling* of the cable back into the *in-cab* panel connector of the tractor.
→ The CCI A3 restarts.

4.1 Problems during operation

This chapter lists problems that may occur during use of the CCI A3. A suggestion is made for rectification for each problem.

- ▶ Try to rectify the problem.
- ▶ Contact your dealer if you cannot resolve the problem.

Problem	Cause/remedy
The CCI A3 does not switch off, if you switch off the tractor ignition.	<p>The tractor does not switch off the supply to the <i>in-cab</i> panel connector.</p> <ul style="list-style-type: none"> ▶ Unplug the <i>in-cab coupling</i> of the cable from the <i>in-cab</i> panel connector of the tractor.
The <i>operating screen</i> of the CCI A3 is not displayed on the ISOBUS terminal.	<p>The ISOBUS terminal is switched on and connected to the ISOBUS, however the UT of the terminal is not activated.</p> <ul style="list-style-type: none"> ▶ Switch the UT of the terminal on. <p>The ISOBUS terminal is not connected to the ISOBUS.</p> <ul style="list-style-type: none"> ▶ Connect the ISOBUS terminal to the ISOBUS. <p>Incorrect configuration of the UT of the ISOBUS terminal.</p> <ul style="list-style-type: none"> ▶ The UT of the ISOBUS terminal must have UT number 1. <p>The <i>in-cab plug</i> on the fixed cable is open.</p> <ul style="list-style-type: none"> ▶ Plug in the <i>terminating resistor</i> included in the scope of delivery.
The operating elements of the CCI A3 are not displayed on the ISOBUS terminal; the <i>AUX assignment</i> cannot be performed.	<p>The ISOBUS terminal and/or the <i>implement</i> are not certified according to AUX-N.</p> <ul style="list-style-type: none"> → If the <i>implement</i> does not support AUX-N, it cannot be operated with the CCI A3. → If the ISOBUS terminal does not support AUX-N, the <i>AUX assignment</i> cannot be performed. <ul style="list-style-type: none"> ▶ Check in the AEF database whether the combination of <i>AUX control</i>, ISOBUS terminal and <i>implement</i> you are using is compatible.
The <i>AUX assignment</i> could be performed, however the CCI A3 does not display any pictograms of the implement functions. The buttons are labelled with F1, F2, F3, etc.	<p>Not all implements display pictograms of the implement functions on the CCI A3.</p> <ul style="list-style-type: none"> → The <i>implement</i> can be operated with the CCI A3. → The buttons trigger the implement functions, that you have assigned to them in the <i>AUX assignment</i>.

5 Disposal

Dispose of a defective or a removed-from-service CCI A3 environmentally and taking into consideration the local regulations:

- ▶ Dispose of plastics with normal domestic waste. **Plastics**

- ▶ Enter metal into a metal recycling chain. **Metal**

- ▶ Deliver the PCBs of the CCI A3 to a specialist recycling company. **PCBs**

Copyright

©2019

Competence Center ISOBUS e.V.

Albert-Einstein-Str. 1

D-49076 Osnabrück

Document number: 20190930