

Installation and User´s Guide

TRAIL-Control II



Imprint

Document

Installation and User's Guide
Product: TRAIL-Control II
Document number: 30293001-02-EN
From software version: 1.01.0a
Original language: German

Copyright ©

Müller-Elektronik GmbH & Co.KG
Franz-Kleine-Straße 18
33154 Salzkotten
Germany
Phone: ++49 (0) 5258 / 9834 - 0
Fax: ++49 (0) 5258 / 9834 - 90
Email: info@mueller-elektronik.de
Homepage: <http://www.mueller-elektronik.de>

Table of contents

1	For your safety	5
1.1	Basic safety instructions	5
1.2	Hazard Area	5
1.3	Safety signs on the machine	6
1.4	Layout and meaning of warnings	6
1.5	User requirements	7
1.6	Intended use	7
1.7	Declaration of conformity	7
2	About these Operating Instructions	8
2.1	Target group of these Operating Instructions	8
2.2	Layout of operating instructions	8
3	Mounting and installation	9
3.1	System overview	9
3.2	Mounting the terminal	10
3.3	Connecting the cable	11
3.4	Connecting the battery connection cable	11
3.5	Mounting the gyroscope	11
3.5.1	Mounting the bracket for the gyroscope	12
3.5.2	Connecting the gyroscope to TRAIL-Control II	12
3.5.3	Using the gyroscope	13
3.6	Instructions on retrofitting	13
4	Product description	15
4.1	Performance description	15
4.2	Minimal preconditions	15
4.3	Overview of keys	15
4.4	Screen structure	16
4.4.1	Structure of work screen	16
	Header area	16
	Main area of work screen	17
	Function icons section	17
4.4.2	Structure of further screens	17
5	Configuring TRAIL-Control II	19
5.1	When should you configure what?	19
5.2	Configuring the basic settings of the on-board computer	19
5.2.1	Setting date / time	20
5.2.2	Setting contrast and brightness	20
5.2.3	Selecting language	21
5.3	Entering the trailed implement parameters	21
5.4	Configuring TRAIL-Control II after tire change	23

5.5	Calibrating the wheel sensor	23
5.5.1	Determining pulses per 100 meters	24
5.5.2	Manually entering the number of pulses for the wheel sensor	25
5.6	Calibrate steering	25
5.6.1	Teaching-in the central position and end stops	25
5.6.2	Calibrating the hydraulics of the proportional valve	28
6	Using TRAIL-Control II in the field	30
6.1	Activating TRAIL-Control II	30
6.2	Steering the trailed implement	30
6.2.1	Steering in manual mode	31
6.2.2	Steering in automatic mode	31
6.2.3	Steering the trailed implement against the slope	31
6.3	Documenting work results	33
7	Locking TRAIL-Control II for road driving	34
8	Maintenance and servicing	35
8.1	Checking the software version	35
8.2	Displaying sensor status	35
8.3	Activating and deactivating hydraulic valves	36
8.4	Maintaining and cleaning device	37
8.5	Disposing of the unit	37
8.6	Technical specifications	37
8.7	Plug assignment - 8-pin flange socket	38
8.8	Plug assignment - 39-pin clip connector	38
8.9	Pin connection of gyroscope connector	39
9	Troubleshooting	40
9.1	Table with possible error messages	40
9.2	Procedure with faults	41

1 For your safety

1.1 Basic safety instructions



Please read the following safety instructions carefully before using the product for the first time.

- Nobody must stay in the proximity of the tractor or trailed implement during operation.
- Never remove any safety mechanisms or stickers from the product.
- Read the operating instructions to the agricultural device which you want to control by using the product.
- Before charging the tractor battery, always disconnect the connection between the tractor and the terminal TRAIL-Control II.
- Before welding on the tractor or implement, always disconnect the power supply to the terminal.
- Before maintenance or repair to the tractor, always disconnect the connection between the tractor and the terminal.
- Do not make any unauthorized modifications to the product. Unauthorized modifications or use may impair safety and reduce the service life or operability of the unit. Modifications are considered unauthorized if they are not described in the product documentation.

1.2 Hazard Area

The **hazard area** covers an area of several meters around the tractor and towed equipment in all directions. The greater the size of the towed equipment, the greater the hazard area. For example: The wider the spraying rods of an agricultural sprayer, the further it can swing out and therefore its hazard area is greater.

	WARNING
	<p>Danger of Injury from Uncontrolled Machine Movements</p> <ul style="list-style-type: none"> ◦ Pay attention that nobody enters the hazard area! ◦ Switch off the system immediately, as soon as a person enters the hazard area!

As soon as the system has been assembled and switched on, nobody may remain in the hazard area.

When the TRAIL-Control II is switched on, there is a risk that pressure fluctuations in the hydraulic system could cause the drawbar or the steering knuckle to move uncontrolledly.

Pressure fluctuations can, for example, occur in the following instances:

- If the hydraulic system is defective
- If the hydraulic system is used for purposes other than for controlling steering of the drawbar and knuckle.

The hazard area may then only be entered if the following conditions are fulfilled:

- The person entering the area must be informed of the potential dangers
- All activities must be precisely agreed between the driver and the person appointed to enter the area.
- All maintenance, configuration and monitoring work must, if possible, be conducted when the system is switched off.

1.3 Safety signs on the machine

You receive a safety sign adhesive label together with the product.

This label must be attached near the bend area with drawbar steering.

When attaching safety signs, observe the following:

- Safety signs must be attached at a visible location so that they can be seen by everyone approaching the danger zone.
- If the danger area can be approached from several sides of the machine, attach the warning signs on all machine sides.
- Regularly check the safety signs for completeness and legibility.
- Replace damaged or unreadable signs with new ones.

Safety sign	Where to attach	Meaning
	Near the the bend area between tractor and trailed implement	Do not stay in the bend area during operation

1.4 Layout and meaning of warnings

All safety instructions found in these Operating Instructions are composed in accordance with the following pattern:

	WARNING
	This signal word identifies medium-risk hazards, which could potentially cause death or serious physical injury, if not avoided.
	CAUTION
	This signal word identifies low-risk hazards, which could potentially cause minor or moderate physical injury or damage to property, if not avoided.

NOTICE

This signal word identifies actions which could lead to operational malfunctions if performed incorrectly.
These actions require that you operate in a precise and cautious manner in order to produce optimum work results.

There are some actions that need to be performed in several steps. If there is a risk involved in carrying out any of these steps, a safety warning will appear in the instructions themselves.

Safety instructions always directly precede the step involving risk and can be identified by their bold font type and a signal word.

Example

1. **NOTICE!** This is a notice. It warns that there is a risk involved in the next step.
2. Step involving risk.

1.5

User requirements

- Learn to operate the product in accordance with the instructions. Nobody must operate the product before reading these Operating Instructions.
- Please read and carefully observe all safety instructions and warnings contained in these Operating Instructions and in the manuals of any connected vehicles and farm equipment.
- If there is anything within these Operating Instructions that you do not understand, please do not hesitate to contact us or your dealer. Müller-Elektronik's Customer Services department will be happy to assist you.

1.6

Intended use

TRAIL-Control II is used exclusively for the steering of agricultural trailed implements during work in fields.

TRAIL-Control II is intended exclusively for use in agriculture as well as in wine-growing, fruit-cultivating, and hop-growing operations. The manufacturer cannot be held responsible for any installation or use of the system that deviates from or exceeds the scope of intended use.

The manufacturer cannot be held liable for any personal injury or property damage resulting from such improper use. All risk involved during improper use lies with the user.

Intended use also includes the adherence to the conditions for operation and repairs prescribed by the manufacturer.

All applicable accident prevention regulations and all other generally recognised safety, industrial, and medical standards as well as all road traffic laws must be observed. Any unauthorized modifications made to the equipment will void the manufacturer's warranty.

Incorrect use:

- TRAIL-Control II must not be used as part of road traffic!

1.7

Declaration of conformity

This product has been manufactured in conformity with the following national and harmonised standards as specified in the current EMC Directive 2004/108/EC:

- EN ISO 14982

2 About these Operating Instructions

2.1 Target group of these Operating Instructions

This operating manual is aimed at users of TRAIL-Control II.

2.2 Layout of operating instructions

The operating instructions explain step by step how you can perform certain operations with the product.

We use the following symbols throughout these Operating Instructions to identify different operating instructions:

Type of depiction	Meaning
1. 2.	Actions that must be performed in succession.
⇒	Result of the action. This will happen when you perform an action.
⇨	Result of an operating instruction. This will happen when you have completed all steps.
☑	Requirements. In the event that any requirements have been specified, these must be met before an action can be performed.

3 Mounting and installation

3.1 System overview

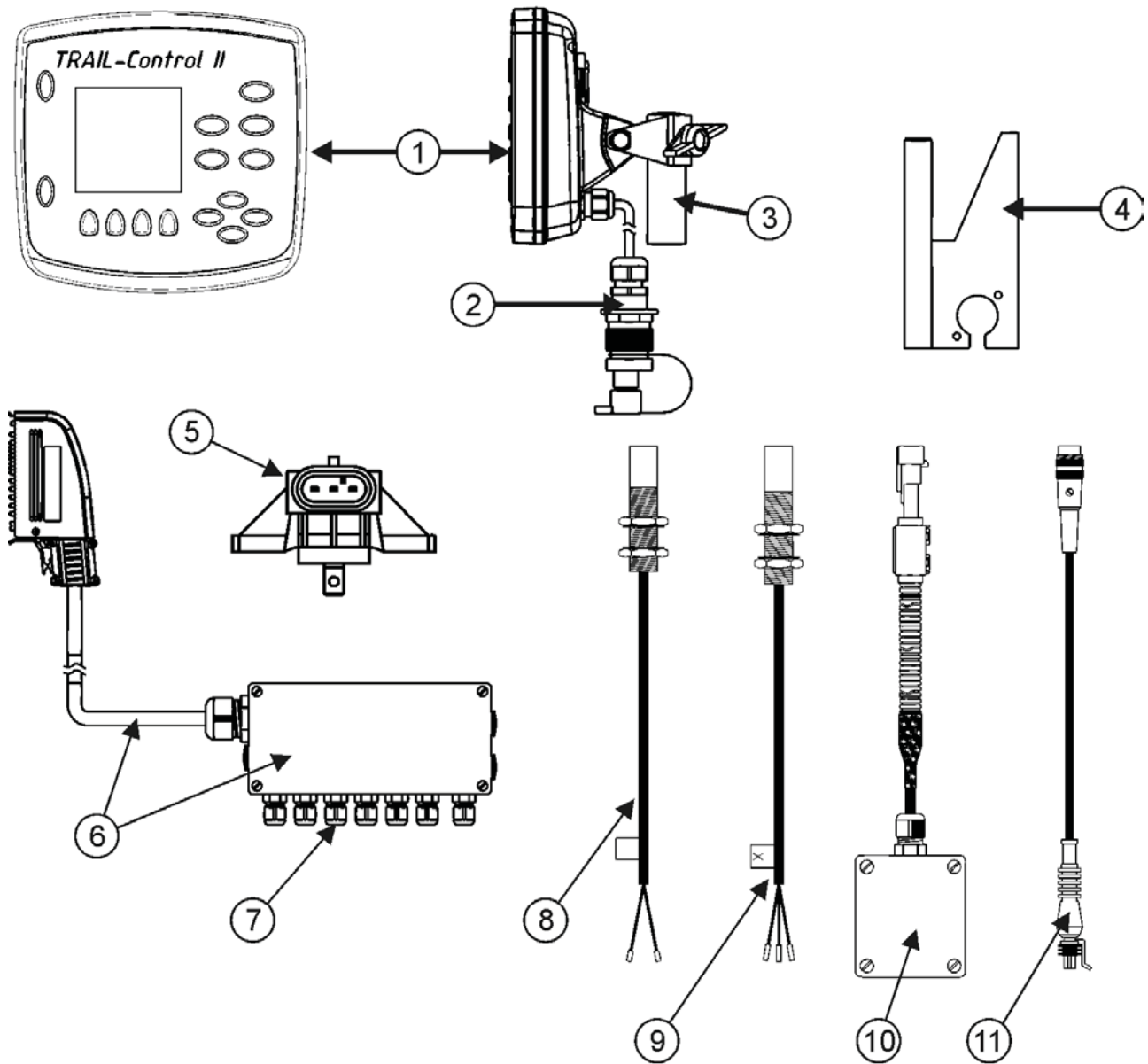

TRAIL-Control II - system overview

①	Terminal / On-board computer Included in delivery	⑦	Cable glands for connecting sections, bypass, regulation, sensors
②	Power connection cable Included in delivery	⑧	Locking sensor Can be ordered. Item no.: 312586
③	Bracket for computer Included in delivery	⑨	Wheel sensor Can be ordered. Item no.: 312600
④	Mounting bracket Can be ordered. Item no.: 312075	⑩	Gyroscope connected Can be ordered. Item no.: 31303160
⑤	Angle sensor Can be ordered. Item no.: 30303675	⑪	Connection cable for gyroscope
⑥	Distributor with connection cable Can be reordered. 10m cable - Item no.: 30293010		

3.2

Mounting the terminal

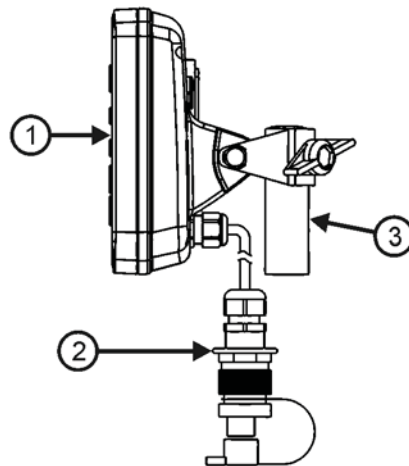

Mounting the terminal

①	Terminal / On-board computer	③	Bracket for mounting the terminal
②	Voltage connection cable Power connection cable with 3-pin connector plug.		

Procedure

1. Screw the bracket ③ to the computer ①.
2. Fasten the bracket with the terminal in the cab of the tractor.
NOTICE! The distance to the radio device or to the radio antenna must be at least one metre.
A mounting bracket can be used to fasten the bracket in the cab.
3. Connect the terminal with the distributor.
4. Connect the power connection cable ② to the battery connection cable.

3.3 Connecting the cable

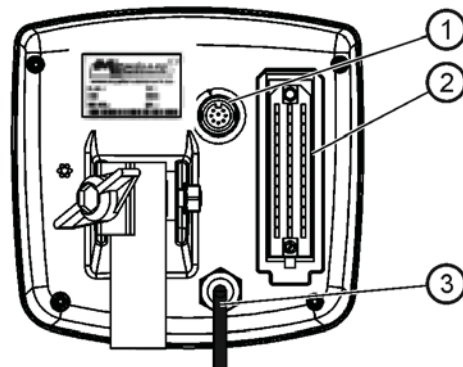

Connections

①	8-pin flange socket for connection of the gyroscope.	③	Connect the power connection cable to the battery connection cable.
②	39-pin multipin connector for connection of the distributor.		

Procedure

1. Connect gyroscope to the 8-pin flange socket ①.
2. Connect distributor to the 39-pin multipin connector ②.
3. Connect the power connection cable ③ to the battery connection cable.

3.4 Connecting the battery connection cable

When connecting the battery connection cable, read the instructions supplied with this cable.

3.5 Mounting the gyroscope

The gyroscope is a measuring device to determine the directional changes of the tractor.

You must mount the gyroscope to use the TRAIL-Control II.

To mount the gyroscope you must carry out the following:

- Mount the bracket on the tractor.
- Connect the gyroscope to the distributor.

3.5.1

Mounting the bracket for the gyroscope



Bracket

Gyroscope in the bracket

Mounting the bracket on the tractor

The bracket on the tractor is used for fastening the gyroscope to the tractor for the duration of work in the field.

Procedure

1. Determine the position for mounting the bracket on the tractor.
The bracket must be mounted vertically and without vibration on the rear of the tractor.
Make sure that the connection cable of the gyroscope does not become too tight when fastened in the bracket.
2. **CAUTION! Before drilling a hole, make sure that for drilling you are not going to damage any cables.**
3. Drill the holes for the screws.
4. Fasten the bracket.
The bracket must be fastened securely to prevent shaking while driving.

3.5.2

Connecting the gyroscope to TRAIL-Control II

Procedure

1. Connect the gyroscope cable with the connection cable.
2. Insert the connection cable into the 8-pin socket of TRAIL-Control II.

3.5.3

Using the gyroscope

Procedure

1. Fasten the gyroscope into the bracket on the tractor and screw tight with the wing screw.
The side with the **TOP-OBEN** label must be on the top:



2. After work, fasten the gyroscope into the bracket on the trailed implement and screw tight with the wing screw.

3.6

Instructions on retrofitting

Instructions on how to retrofit electrical and electronic farm equipment and/or components

Agricultural equipment used today features electronic components and parts whose function can be affected by other farm equipment which emits electromagnetic waves. Such effects could lead to personnel being put in danger, if the following safety instructions are not adhered to.

Selecting components

When selecting components, make sure first of all that the retrofitted electrical and electronic components comply with the current version of the EMC Directive 2004/108/EC and carry the CE marking.

User responsibility

When retrofitting a machine with electrical and electronic farm equipment and/or components connected to the vehicle's electrical system, it is your own responsibility to check whether the installation causes interference with the vehicle's electronic system or other components. This applies, in particular, to the electronic control of:

- electronic hitch control,
- front linkage,
- power take off (PTO),
- engine,
- gear.

Additional requirements

The following requirements must be met in order to retrofit mobile communication systems (e.g. radio, phone):

- All farm equipment must be approved and installed in accordance with the regulations applicable in the respective country.
- The equipment must be installed as a fixed installation.
- The operation of portable or mobile farm equipment in the interior of the vehicle is only permitted via a connection to a permanently installed exterior antenna.

- The transmitting part must be spatially separated from the vehicle's electronic system.
- When attaching the antenna, pay attention to proper installation, including a sound ground connection between the antenna and the vehicle's ground wire.

For information on wiring and installation as well as the maximum allowable current consumption, please also refer to the installation guide provided by the machine manufacturer.

4 Product description

4.1 Performance description

TRAIL-Control II features the following functions:

- Steering for a trailed implement:
 - Drawbar steering
 - Stub axle steering
- Slope counter-steering: Steering of a trailed implement against a slope, with work on inclined ground

4.2 Minimal preconditions

The following minimal preconditions must be met for working of the TRAIL-Control II:

- Minimal speed = 3 km/h. Steering is not possible with lower speeds.
- Minimal oil throughput for the hydraulic system of the tractor = 25 l/min.

4.3 Overview of keys



TRAIL-Control II on-board computer - front view

Controls

Buttons – Buttons always having the same function. Named 'buttons' from now.

- Switch on-board computer on and off
- Switch all functions of TRAIL-Control II on and off
- Steer the trailed implement into the central position
- Switch between manual and automatic mode
- Steer trailed implement to the left when the tractor drives to the right
- Steer trailed implement to the right when the tractor drives to the left
- Has no function

- In the menus – move the cursor up one line
Increase the value by one during data input
- In the menus – move the cursor down one line
Reduce the value by one during data input
- Exit screen
Cancel data input
Close a pop-up window
- Confirm data input and finish

Function buttons – Buttons, the function and meaning of which depends upon the symbols (function symbols) displayed on the screen. Function buttons may have different functions in different screens. Named 'function buttons' from now.

- Activate the functions represented by the function icons

4.4 Screen structure

4.4.1 Structure of work screen

The work screen is always displayed during work and contains the most important information. The work screen informs you about the status of the connected machine during work.

The appearance of the work screen depends upon whether your trailed implement is steered via drawbar or swivel pin.

The following figure shows three areas of the work screen.

The figure shows all symbols that can be displayed by the screen. During work, only some of the symbols are displayed simultaneously.

Explanations for the symbols are found in the following sections.

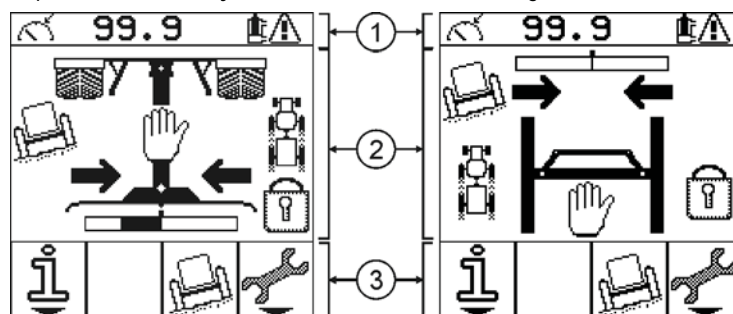

Areas of the work screen with steering via drawbar (left) and via swivel pin (right)

①	Header area	③	Function icons section
②	Main area of work screen		

Header area

The following information is shown in this area:

- Symbol for the simulated speed activated function
- Current speed









- Warning symbol: The warning symbol appears when you have not calibrated the proportional valve.

Main area of work screen

In the main area of the work screen, symbols are displayed that inform you about the current status of steering.

Icons

The following symbols can appear in this area:

Icon	Meaning
	Manual mode is activated.
	Automatic mode is activated
	'Slope counter-steering' function is activated
	Trailed implement is steered to the left when the tractor drives to the right
	Trailed implement is steered to the right when the tractor drives to the left
	Actual state of the angle sensor Pick-up bar of the angle sensor in central position
	Actual state of the angle sensor – with steering to left Shows in which direction and how strong the pick-up bar of the angle sensor swings out.
	Drawbar was locked with the locking sensor

Function icons section

The lower area of the work screen shows the function symbols. The lower area of the work screen shows the function symbols. With TRAIL-Control II, four function symbols can be shown simultaneously here.

Controls



Call up counter screen



Activate 'slope counter-steering' function



Change to Parameter 1 screen

4.4.2

Structure of further screens

In addition to the work screen, further screens are displayed with TRAIL-Control II.

These screens always consist of the following three areas:

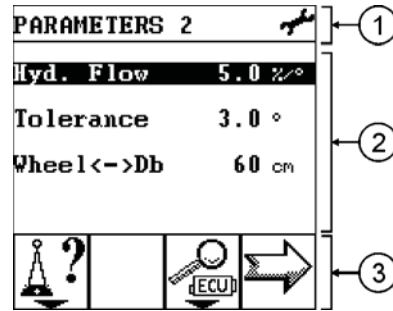

Screen structure

①	Header area contains the designation of the displayed screen	③	Function symbol area Icons that can be pressed on this screen.
②	Screen content		

5 Configuring TRAIL-Control II

After you have connected all components of the system, you must configure TRAIL-Control II and the connected components.

To configure the system, you must carry out the following:

- Configure the on-board computer.
- Enter the machine parameters
- Calibrate the sensors
- Calibrate the steering hydraulics

5.1 When should you configure what?

The following table shows an overview of the configurable functions and when these functions must be configured:

When should you configure what?

Function	First start-up	Start of season	In other instances
Date / time	•		Changing the clocks. After more than two weeks without power.
Language	•		
Contrast and brightness	•		
Compensation time (optional)	•		
Hydr. output (optional)	•		When the steering starts jerkily
Tolerance	•		
Wheel<->Db	•		When you change tractors
Wheel type			When you use more than one wheel set or tire set
Trace width	•		With change of track width
Calibrating the wheel sensor	•	•	Displayed speed differs from actual speed.
Calibrate steering	•		When the steering is not precise.

5.2 Configuring the basic settings of the on-board computer

To configure the basic settings, you must carry out the following:

- Select the language

- Set contrast and brightness
- Set date / time

The following sections contain detailed instructions.

5.2.1

Setting date / time

When to enter?

- Prior to initial startup.
- When TRAIL-Control II has had no power supply for more than two weeks.

Procedure

1. Change to the **Date/time** screen:



⇒ The following screen will appear:

DATE/TIME	
Day:	14
Month:	01
Year:	10
Hour:	22
Minute:	24

2. Modify the required parameters.

⇒ The new date and time appear on the screen Parameter 1

5.2.2

Setting contrast and brightness

Procedure





1. Change to **Display** screen:

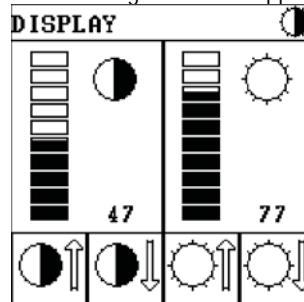

⇒ The following screen will appear:



2. Configure the screen via the following function buttons:

-  - Increase contrast
-  - Reduce contrast
-  - Increase brightness
-  - Reduce brightness

3.  - Exit the screen.

⇒ The modifications are adopted.

⇒ You have adjusted contrast and brightness of the screen.

5.2.3 Selecting language

You can choose from the following languages:

- Danish
- German
- English
- French
- Italian
- Dutch
- Polish
- Portuguese
- Swedish
- Spanish
- Czech
- Hungarian

Procedure

1. Change to **Language 1** screen



⇒ The following screen will appear:



2. - mark the required language.
3. - If you cannot find your language on the first page, call up the next page.
4. - Confirm.
5. - Restart the on-board computer.

⇒ The on-board computer language is modified.

5.3 Entering the trailed implement parameters

Before you use TRAIL-Control II, you must enter the parameters for the connected trailed implement.





Procedure

1. Change to **Parameters 2** screen

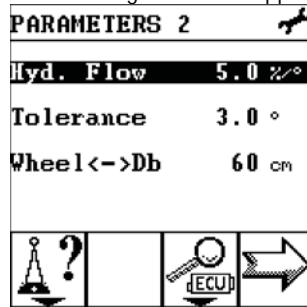

⇒ The following screen will appear:



2.   - Mark the line with the required parameter.
3.  - Enter the required parameter.
4.  - Change to **Parameters 3** screen
5. Enter the required parameter in the **Parameters 3** screen.

The following tables contain an overview and explanation of the settable parameters.

Parameter 2 screen

Parameter	Description
Comp. time	Compensation time Enter only for trailed implements with bang bang hydraulics. The greater the value, the earlier cornering is commenced in automatic mode. The lesser the value, the later cornering is commenced in automatic mode. Normally the value is between: 700ms and 1000ms.
Hyd. Flow	Hydraulic Flow Enter only for trailed implements with a proportional valve. Hydraulic output is a value for setting the steering speed. Normally the value is between: 1.5%/° and 3%/°
Tolerance	The tolerance influences the behaviour of steering in the central position area. The lower the tolerance is set, the more sensitive the control is to small changes. Normally the value is between: 2° and 3°
Wheel<->Db	Wheel<->Db Distance between the center of the rear axle of the tractor and the towing hook of the tractor.

Parameter 3 screen

Parameter	Description
Wheel	Select the number of a wheel set The parameters 'Wheel.pls' and 'Track width' change for each wheel type.
Wheel.pls	If you know the number of pulses for the wheel sensor you can enter this

Parameter	Description
	manually.
Track width	Track width of the machine

5.4 Configuring TRAIL-Control II after tire change

The following machine parameters change after any tire or wheel replacement:

- Wheel.pls
- Track width

You can configure up to three wheel sets to prevent having to re-enter these parameters after each tire or wheel change.

Procedure

1. Change to **Parameters 3** screen



⇒ The following screen will appear:

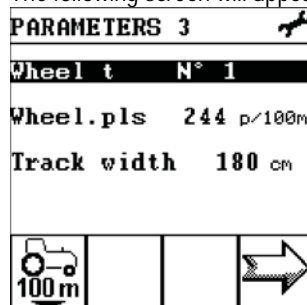

2. In the **Wheel t** line, select the number of the wheel set to be configured.
3. Calibrate the wheel sensor for this wheel set.
4. Enter the track width for this wheel set.
⇒ The wheel.pls and track width parameters are saved for the configured wheel set.
5. With every use of these tires or wheels, select the number in the **Wheel t** line again with which the tires are configured.

5.5 Calibrating the wheel sensor

When should you calibrate?

- Prior to initial startup.
- After changing tires.
- When the speed shown on the work screen is incorrect.

NOTICE

Imprecise calibration

The speed cannot be precisely determined with an incorrectly calibrated wheel sensor. This makes all calculations imprecise.

- Calibrate the wheel sensor very precisely.

5.5.1

Determining pulses per 100 meters

When calibrating the wheel sensor with the 100m method, you determine the number of pulses received by the sensor over a distance of 100 meters.

When you know the amount of impulses, the TRAIL-Control II can calculate the current speed.

In order for the wheel sensor to function correctly, it must receive at least 250 pulses over a distance of 100 metres. With very long machines, even 300 pulses per 100 metres.

To increase the number of pulses, you must mount additional magnets opposite of the wheel sensor.

Preconditions





- Wheel sensor is mounted.
- All wheel sensor magnets are fully functional.
- A distance of 100m has been measured and marked. The distance must correspond to the field conditions. It should therefore lead over a meadow or a field.
- The tractor with connected implement is ready for a 100m drive and is at the start of the marked distance.

1. Ensure that all prerequisites have been fulfilled.
2. Change to **Wheel.Puls** screen:

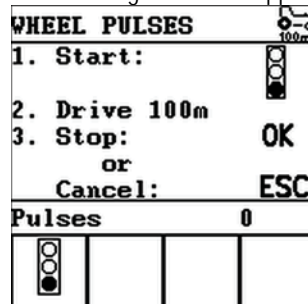

⇒ The following screen will appear:



3.  - Start calibration.
4. The following function icons appear:
 -  - Stop calibration.
 -  - Abort calibration.
5. Drive the previously measured 100m distance and stop at the end.
 - ⇒ During the drive, the currently determined pulses are displayed. At the end of the distance at least 250 pulses should appear on the screen. If less pulses are shown, you must mount more magnets to the wheel.
6.  - Stop calibration.

7.  - Exit the screen.

⇒ You have calibrated the wheel sensor.

5.5.2

Manually entering the number of pulses for the wheel sensor

If you know the number of pulses for the wheel sensor you can enter this number manually as well.

Procedure

1. Change to **Parameters 3** screen

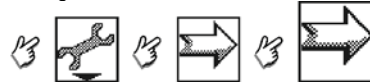

⇒ The following screen will appear:

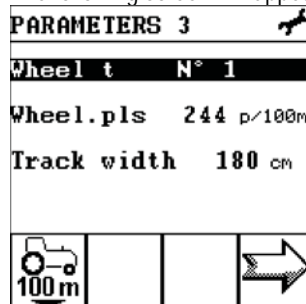

2. Enter the number of pulses in the **Wheel.pls** line.

⇒ You have manually entered the number of pulses.

5.6

Calibrate steering

When should you calibrate?

- Prior to initial startup.
- At the start of each season.
- When inaccuracies occur.

There are two methods to calibrate the steering:

- **Teaching-in the central position and end stops**

This method is suitable for implements without proportional valves.

With this method you teach the On-board computer the position of the drawbar or swivel pin in the central position as well as the left and right end stops.

All intermediate positions are calculated by the On-board computer itself.

- **Calibrating the hydraulics of the proportional valve**

This method is suitable for implements with proportional valves.

With this method the trailed implement is automatically steered to both sides and the voltage is measured.

Calibration with this method is automatic.

5.6.1

Teaching-in the central position and end stops

The appearance of the screens during calibration depends upon whether your trailed implement is steered via drawbar or swivel pin.

The procedure is however identical for both cases.

Phase 1 Teach-in central position

1.  - Set up the trailed implement on flat ground in a line behind the tractor.

2. Change to the TRAIL-Control screen:



or when the angle sensor is mounted to the swivel pin:



⇒ The following screen will appear:

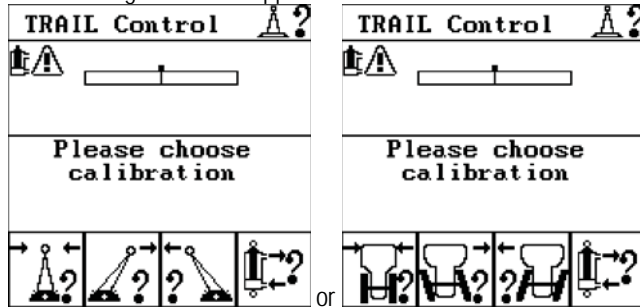

3. or - Call up the calibration of the central position.

⇒ The following screen will appear:

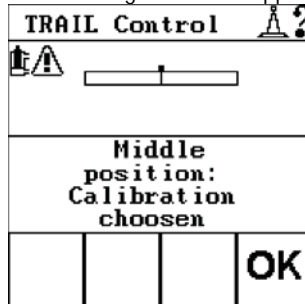

4. - Confirm within three seconds.

⇒ Calibration is initiated.

⇒ The following screen will appear:

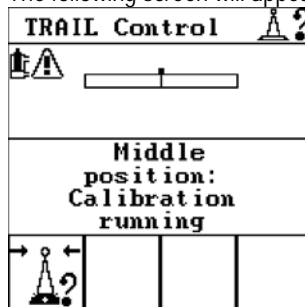

⇒ Phase 1 is completed when the message 'Central position: calibration runs' is no longer displayed.



⇒ You have calibrated the central position.

⇒ You can start phase 2 of the calibration.

Phase 2 Teach-in end stops

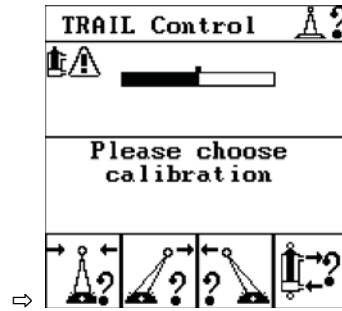
1. - Steer the trailed implement maximally to the left.



2.  or  - Start calibration.

⇒ The following screen will appear:

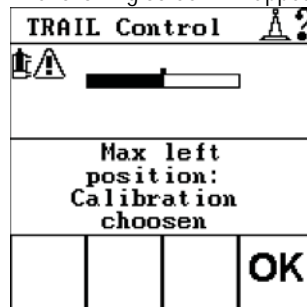

3.  - Confirm within three seconds.

⇒ Calibration is initiated.

⇒ The following screen will appear:



4. Wait until the message 'Left maximum position: calibration runs' is no longer displayed.

⇒ The following screen will appear:



5.  - Steer the trailed implement maximally to the right.

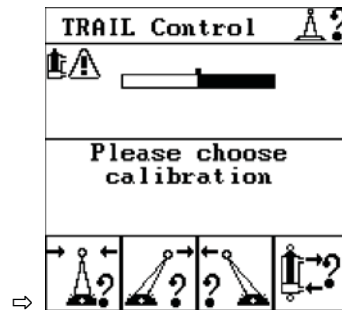

6. or - Start calibration.
 ⇒ The following screen will appear:

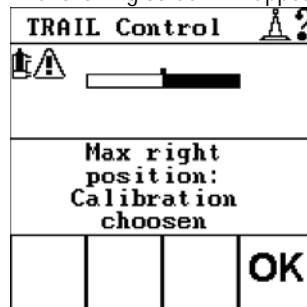

7. - Confirm within three seconds.
 ⇒ Calibration is initiated.
 ⇒ The following screen will appear:





8. Wait until the message 'Right maximum position: calibration runs' is no longer displayed.
 ⇒ The following screen will appear:





⇒ Phase 2 of calibration has been completed.

5.6.2 Calibrating the hydraulics of the proportional valve

You must only calibrate the hydraulics of the proportional valve when you use a trailed implement with proportional valve.

	 WARNING
	<p>Danger of injury from machine movements</p> <p>When calibrating the proportional valve, the machine moves automatically in the bend area. This may cause danger for you and for persons in direct proximity to the machine.</p> <ul style="list-style-type: none"> ◦ Ensure that nobody is in the regulation range of the machine. ◦ Abort the calibration with the function button  as soon as someone approaches the machine.

Procedure

1.   - Steer the machine into central position.

2.  - Start calibration.

⇒ The following screen will appear:

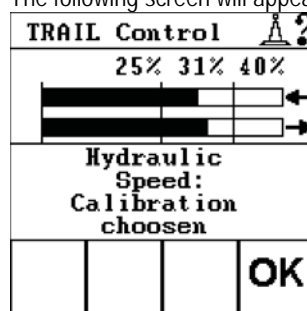

3.  - Confirm within three seconds.

⇒ The following screen will appear:

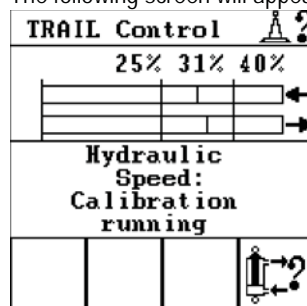

⇒ The drawbar now moves slowly to the left and then slowly to the right.



⇒ This procedure may last up to 20 seconds.

⇒ Phase 3 is completed when the message 'Hydraulics calibration runs' is no longer displayed.

6 Using TRAIL-Control II in the field

6.1 Activating TRAIL-Control II

Procedure

1.  - Switch on TRAIL-Control II.
 ⇒ A blue screen with the text 'TRAIL CONTROL II' appears.
 In this condition, all TRAIL-Control II functions are locked.
 2.  - Enable all functions of TRAIL-Control II.
 ⇒ The work screen appears.
 ⇒ Error messages may appear here when sensors are faulty or incorrectly connected. More about this in section: Table with possible error messages [→ 40]
- ⇒ You have activated TRAIL-Control II.

6.2 Steering the trailed implement

TRAIL-Control II lets you work in two modes:

- in automatic mode
- in manual mode

Controls



Switch between manual and automatic mode

Mode of operation

The TRAIL-Control function controls the trailed implement. Here the direction in which the trailed implement is steered is the reverse of the direction in which the tractor is steered.

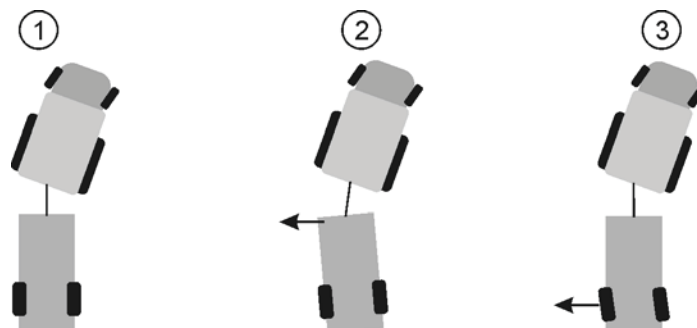

Steering a trailed implement in a curve

	Trailed implement without steering		Trailed implement with swivel pin steering
	Trailed implement with drawbar steering		

The figure shows that the trailed implement must always be steered in the opposite direction to the direction of the tractor. Only in this way can the implement remain in the tracks of the tractor.

Minimum work speed

The minimum work speed for TRAIL-Control II is 3 km/h.

Speeds lower than this mean the system does not function optimally.



6.2.1 Steering in manual mode

You can use manual mode to steer the trailed implement in the following situations:

- Steering the trailed implement when driving forwards
- Steering the trailed implement when driving backwards
- Steering the trailed implement into the central position



	<p>! WARNING</p>
	<p>Danger of injury from trailed implement movement The complete implement moves during steering. This may cause danger for persons and materials in direct proximity to the implement.</p> <ul style="list-style-type: none"> ◦ Ensure that nobody is in the range of the implement before steering the implement.

Controls

-  Steer trailed implement to the left when the tractor drives to the right
-  Steer trailed implement to the right when the tractor drives to the left
-  Steer the trailed implement into the central position

You can see the progress on the work screen.

Procedure

1. Driving the tractor to the right
2.  - Steer the trailed implement for driving to the right.
 - ⇒ With drawbar steering: The drawbar is steered to the left.
 - ⇒ With stub axle steering: The wheels are steered to the left.
3. Drive the tractor straight ahead.
4.  - Steer the trailed implement into the central position
 - ⇒ The trailed implement moves slowly into central position
5. Driving the tractor to the left
6.  - Steer the trailed implement for driving to the left.
 - ⇒ With drawbar steering: The drawbar is steered to the right.
 - ⇒ With stub axle steering: The wheels are steered to the right.

6.2.2 Steering in automatic mode

When you work in automatic mode the trailed implement is steered automatically.

The gyroscope measures the directional change of the tractor and TRAIL-Control II calculates the required angle for steering the trailed implement.

6.2.3 Steering the trailed implement against the slope

For work on a slope you can use the 'slope counter-steering' function.

When you activate the 'slope counter-steering' function you can offset the track of the trailed implement to the left or right. The direction in which the track is offset depends if the slope climbs or declines to the left or right of the vehicle.

The aim of the 'slope counter-steering' function is to avoid the trailed implement driving inclined to the direction of work on a slope.

①

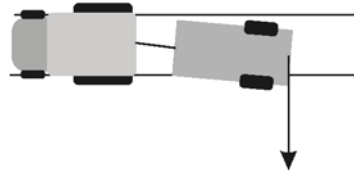

②

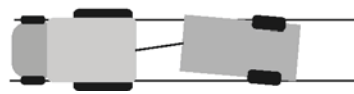

Steering the implement against the slope

③

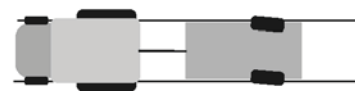

①	Without TRAIL-Control II	③	TRAIL-Control II with swivel pin steering
②	TRAIL-Control II with drawbar steering		

Using slope counter-steering in manual mode

In manual mode you must steer the trailed implement manually against the slope. Here you can decide yourself whether the trailed implement should follow the track of the tractor or whether it should be offset.

Procedure

- Activate 'slope counter-steering' function.

⇒ The work screen displays the icon

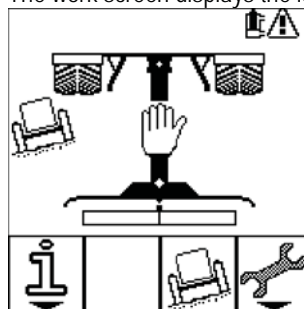

- Steer the trailed implement against the slope.
When the slope inclines to the left of the vehicle you must steer the trailed implement to the left.
When the slope inclines to the right of the vehicle you must steer the trailer device to the right.
- Deactivate 'slope counter-steering' function.

Using slope counter-steering in automatic mode

In automatic mode the TRAIL-Control II determines itself how far the machine must be steered against the slope.

Procedure



- You have installed a tilt sensor.

- Activate 'slope counter-steering' function.

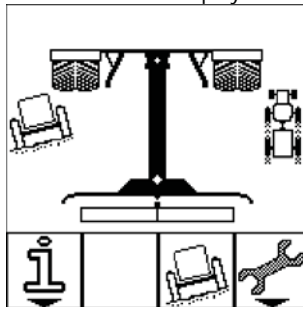
⇒ The work screen displays the icon 



⇒ The trailed implement is automatically steered against the slope.

2.   - Readjust the position of the trailer device.

3.  - Deactivate 'slope counter-steering' function.

6.3

Documenting work results

There are two types of meters for documenting work and evaluating this:



- Day counter – documents the work until it is deleted.
- Total counter – documents the work since first start-up.

Path



Both types of counters are found on the **Counter** screen.

The first two lines are for the daily counter.

Counter 			
Time	7.2 h		
Distance	90.62 km		
Total			
Time	19 h		
Distance	145 km		
Serv hours	92 h		
			

Counter screen

The **Counter** screen has the following information:

- Time – time period of TRAIL-Control II in automatic mode.
- Distance – distance driven in automatic mode.
- Serv hours– time period in which TRAIL-Control II was switched on.

Controls





Delete day meter time







Delete day meter distance

7 Locking TRAIL-Control II for road driving

Before driving the machine on a public road you must deactivate machine steering, and if possible lock with the locking sensor.

	 WARNING
	<p>Risk of accident from activated machine steering</p> <p>The machine steering in road traffic can lead the pulled machine to the side of the tractor track. This may cause a traffic accident.</p> <p>Before driving the machine on a road:</p> <ul style="list-style-type: none"> ◦ Steer the machine into central position! ◦ Switch off TRAIL-Control II!

Procedure

1.  - Activate manual mode.
2.  - Steer the trailed implement into the central position.
3. If you have locking bolts: Lock drawbar steering with the locking bolts.
4.  - Disable all functions of TRAIL-Control II.
⇒ A blue screen appears with the text 'TRAIL-Control II'.
5.  - Switch off TRAIL-Control II.
⇒ TRAIL-Control II is ready for road traffic.

8 Maintenance and servicing

NOTICE

This product does not contain any components which require maintenance or repair!
Never unscrew the casing!

8.1 Checking the software version

Procedure

1. Change to **Diagnostic Info** screen



⇒ The following screen will appear:



⇒ The following information may appear on the screen:

- SW: Software version
- OP: "Object Pools" version (icons and graphics)

8.2 Displaying sensor status

The screens in this area contain information that is mainly of interest for customer service.

you can read out the condition of sensors in the Inputs 1 screen.

This screen shows the current voltage at the sensors in millivolts. When voltage is too high or too low, an error message appears informing that the corresponding sensor is faulty.

Procedure

1. Change to **Inputs 1** screen:



⇒ The following screen will appear:

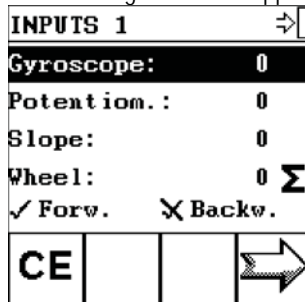

2. - To change to the Inputs 2 screen.

⇒ The following screen will appear:

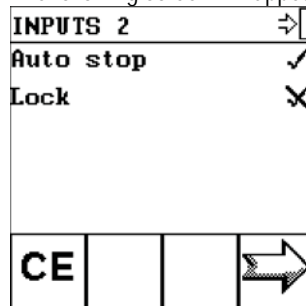

Depending on the system's configuration, different sensors may be displayed here:

Sensor displayed	Displayed sensor value	Meaning
Gyroscope	current measurement value	current voltage in mV
Potent.: (angle sensor)	current measurement value	current voltage in mV
Tilt (tilt sensor)	current measurement value	current voltage in mV
Wheel	current measurement value	Total sum of pulses since last resetting
Forwds.	Activated/deactivated	Shows in which direction the trailed implement moves.
Backwrds.	Activated/deactivated	Shows in which direction the trailed implement moves.
Auto off	activated	Shows whether automatic switch-off is activated.
Locking	Activated/deactivated	Shows whether drawbar locking is activated.

Controls



Reset the wheel sensor to 0



Change to the next screen:

8.3

Activating and deactivating hydraulic valves

If irregularities occur, a service technician can open and close the individual hydraulic valves.

Procedure

1. Change to **Outputs 1** screen



⇒ The following screen appears:

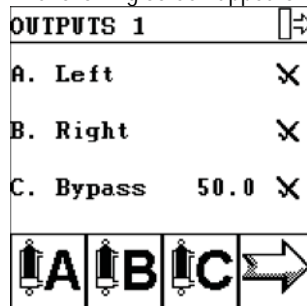

Each output corresponds to one hydraulic valve.

The current degree of the opening in percent appears in addition to the designation of the hydraulic valve.

2. Press the function buttons to activate the required hydraulic valves.

As well as the output designations, the following symbols are displayed:



- Hydraulic valve is activated.



- Hydraulic valve is deactivated.

3.  - Exit **Outputs 1** screen.

⇒ You have activated the desired hydraulic valves.

8.4 Maintaining and cleaning device

- Only clean TRAIL-Control II with a soft damp cloth wet with clear water or glass cleaner.

8.5 Disposing of the unit



When it has reached the end of its service life, please dispose of this product as electronic scrap in accordance with applicable EU legislation.

8.6 Technical specifications

Parameter	Value
Operating voltage	10 - 30 V
Operating temperature	-20 – +70 °C
Storage temperature	-30 – +80 °C
Weight	1 kg
Dimensions (W x H x D)	170 x 165 x 90 mm
Protection class	IP 54 in accordance with DIN 40050/15
EMC	In accordance with ISO 14982 / PREN 55025 Interference suppression level 4

Parameter	Value
ESD protection	In accordance with ISO 10605 Level 3
Power input	5 Watt (no valves connected)
Display	160 x 160 pixel LCD display, transfective with white LED backlighting; software-controlled contrast, brightness and temperature compensation
Processor	60 MHz ARM7 LPC2214 with internal 256k flash disk and 16k RAM
RAM	1MB
Boot USB	2MB
Serial FRAM	8kB
Internal clock	Buffered by capacitor, keeps the time for 2 weeks without an external power supply.
Keyboard	14 keys plus On/off key, all backlit
Outputs	3 highside switches with maximum 2.5A each 1 motor bridge with maximum 5A

8.7

Plug assignment - 8-pin flange socket

These abbreviations are used in the following table:

- VE – Electronics voltage
- VL – Power voltage

8-pin flange socket Pin no.	Signal	8-pin flange socket Pin no.	Signal
1		5	Sig. Gyroscope
2	+12 VE	6	
3	0 VE	7	RS232: RxD
4		8	RS232: TxD

8.8

Plug assignment - 39-pin clip connector

These abbreviations are used in the following table:

- VE – Electronics voltage
- VL – Power voltage

39-pin connector Pin no.:	Signal	39-pin connector Pin no.:	Signal	39-pin connector Pin no.:	Signal
A1	TC ON / OFF	B1			Magnetic valve, right 1
A2	TC OFF / ON				Bypass out
A3					Magnetic valve, left 1
A4					Free
A5	Magnetic valve, left 2				Hand operation
A6	Free				Gyroscope
A7	Magnetic valve, right 2				12 VE
A8	Free				Wheel sensor 1
A9	Drawbar locking		12 VL		0 VE
A10	Center position		Ground		Wheel sensor 2
A11			Ground		Tilt sensor
A12			Ground		Locking
A13			Ground		Angle sensor / drawbar poti

8.9

Pin connection of gyroscope connector

Pin connection of gyroscope connector:

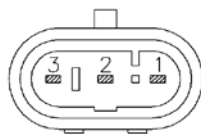

3-pin connector of gyroscope

①	GNDE / mass electronics	③	Signal
②	+12 V		

9 Troubleshooting

9.1 Table with possible error messages

It may occur that a warning message or warning symbol appears on the terminal screen during work.

- Warning symbols appear in the header of the work screen.
- Warning messages appear in a pop-up window.

The following table lists possible error messages and a short help to remedy the fault.

Error message	Possible cause	Help
	Incorrectly configured proportional valve	Contact customer service.
Tilt sensor incorrectly mounted	Tilt sensor is not connected but configured. Sensor voltage is not as expected.	Reset the tilt sensor configuration to works settings.
Drawbar poti is incorrectly mounted	Angle sensor is defect or not connected. Sensor voltage is not as expected.	Contact customer service.
Gyroscope incorrectly mounted	Gyroscope not connected. Sensor voltage is not as expected.	Check the gyroscope connections
Drawbar poti inverted	Cable is incorrectly connected to the angle sensor	
	Wrong settings in the password-protected area	Contact customer service.
Calibration required	Calibration is no longer up-to-date	Calibrate the machine steering
Check parameters		
Drawbar poti defective (angle sensor defective)	Sensor voltage is not as expected.	Check condition of the sensors
Gyroscope defective	Sensor voltage is not as expected.	Check condition of the sensors
Angle sensor defective	Sensor voltage is not as expected.	Check condition of the sensors
Speed too high	The maximum speed of 15km/h	Drive more slowly or switch off

Error message	Possible cause	Help
	was exceeded.	TRAIL-Control II.
Sensors faulty	Short signal interruptions with all sensors.	Check cabling of the sensors.

9.2 Procedure with faults

Fault description	Possible cause	Help
The device does not switch on	Incorrect power supply polarity	Check the battery connector cable.
	Interruption in the power supply.	Check the battery and fuse terminals.
	Total failure	Replace the device
Machine drives with activated control (auto, central position, manual) to the mechanical end stop	Angle sensor is defected or mechanically incorrectly mounted.	Check angle sensor with a multimeter. Readjust if necessary or replace.
The track is not maintained or the machine sways around the central position	Machine parameters entered incorrectly or calibration is faulty	Check the machine parameters, Calibrate steering
	Towing eyelet has too much play	Use sleeve
Steering does not respond	"End Stops" incorrectly set	Calibrate steering
	Hydraulics not switched on or tubes incorrectly coupled	Switch on hydraulics, check tube connections
The machine sways onwards after exiting a curve.	Very large inert mass of the rod creates negative pressure in the hydraulic system and therefore a shifting of the cylinder	- Use loadholding valve. - Check whether the pick-up bar at the angle sensor is correctly mounted.
Central position is incorrect	Angle sensor adjustment has changed	Calibrate steering
No speed is displayed	Missing pulse/100m input	Input number of pulses/100m
	The wheel sensor does not send any pulses to the computer.	Set the distance between the wheel sensor and the magnet at 5-10 mm.
		The red site of the magnet must face the sensor.
		Sensor is faulty, replace